

Durofix

RY6001

ROTARY HAMMER DRILL

PRODUCT INFORMATION MANUAL



THIS MANUAL CONTAINS IMPORTANT INFORMATION REGARDING SAFETY, OPERATION, MAINTENANCE AND STORAGE OF THIS PRODUCT.

DO NOT ATTEMPT TO OPERATE THE TOOL UNTIL YOU HAVE READ AND UNDERSTOOD ALL INSTRUCTIONS AND SAFETY RULES CONTAINED IN THIS MANUAL. FAILURE TO COMPLY MAY RESULT IN ACCIDENTS INVOLVING FIRE, ELECTRIC SHOCK, OR SERIOUS PERSONAL INJURY. SAVE THIS OWNER'S MANUAL FOR FUTURE REFERENCE AND REVIEW IT FREQUENTLY FOR SAFE

OPERATION.

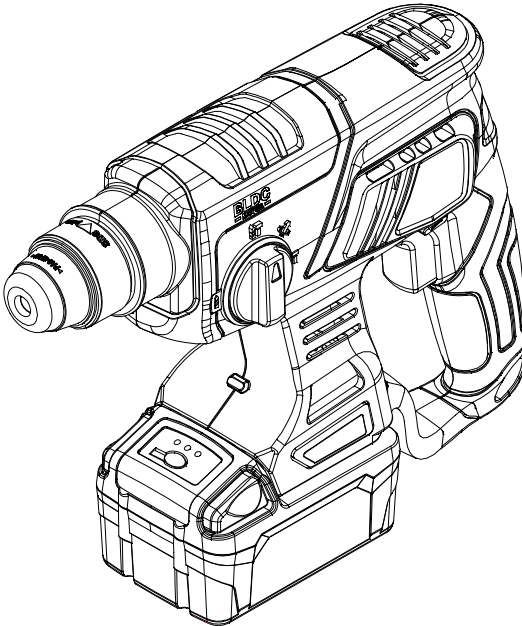

Original Instructions



THANKS FOR CHOOSING THIS PRODUCT

Durofix provides you with products at an affordable price, and we would like you to be fully satisfied with this product and our technical support. If any help or advice is needed, please kindly contact us.

INTENDED USE

This tool is intended for personal use only.

This Impact Wrench is designed to remove and install threaded fasteners.

GENERAL SAFETY RULES



WARNING

Read all safety warnings, instructions, illustrations and specifications provided with this power tool. Failure to follow all instructions listed below may result in electric shock, fire and/or serious injury. The term "power tool" in all of the warnings listed below refers to your mains-operated (corded) power tool or battery-operated (cordless) power tool.

SAVE THESE INSTRUCTIONS FOR FUTURE REFERENCE

RECOGNIZE SAFETY SYMBOLS, WORDS AND LABELS

The safety instructions provided in this manual are not intended to cover all possible conditions and practices that may occur when operating, maintaining and cleaning power tools.

Always use common sense and pay particular attention to all the **DANGER**, **WARNING**, **CAUTION** and **NOTE** statements of this manual.



This is the safety alert symbol. It is used to alert you to potential personal injury hazards. Obey all safety messages that follow this symbol to avoid possible injury or death.



DANGER

DANGER indicates an imminently hazardous situation which, if not avoided, will result in death or serious injury.



WARNING

WARNING indicates a potentially hazardous situation which, if not avoided, could result in death or serious injury.



CAUTION

CAUTION indicates a potentially hazardous situation which, if not avoided, may result in minor or moderate injury.

NOTE

NOTE provides additional information that is useful for proper use and maintenance of this tool. If a **NOTE** is indicated make sure it is fully understood.

WARNING LABEL IDENTIFICATION



Read Manuals Before Operating Product.



Wear Eye Protection.



Wear Hearing Protection.



Wear Dust Mask.



Power tools can vibrate in use.



Keep body stance balanced and firm. Do not overreach when operating this tool.



Recycling



Do not drop the battery and charger into trashcan.

IMPORTANT SAFETY RULES

DANGER

When using the vibrator always prevent exposure and breathing of harmful dust and particles.

WARNING: Some dust created by power sanding, sawing, grinding, drilling and other construction activities contains chemicals known to the State of California to cause cancer, birth defects or other reproductive harm.

Some examples of these chemicals are:

- Lead from lead-based paints.
- Crystalline silica from bricks and cement and other masonry products, and arsenic and chromium from chemically-treated lumber.

Your risk from these exposures varies, depending on how often you do this type of work. To reduce your exposure to these chemicals: work in a well ventilated area, and work with approved safety equipment, such as dust masks that are specially designed to filter out microscopic particles.

WARNING: Handling the power cord on corded products may expose you to lead, a chemical known to the State of California to cause cancer and birth defects or other reproductive harm. *Wash hands after handling.*

WORK AREA

WARNING

Keep work area clean and well lit. Cluttered and dark areas invite accidents.

Do not operate power tools in explosive atmospheres, such as in the presence of flammable liquids, gases or dust. Power tools create sparks which may ignite the dust or fumes.

Keep children and bystanders away while operating a power tool. Distractions can cause you to lose control.

ELECTRICAL SAFETY

WARNING

- a. **Avoid body contact with earthed or grounded surfaces such as pipes, radiators, ranges and refrigerators.** There is an increased risk of electric shock if your body is earthed or grounded.
- b. **Do not expose power tools to rain or wet conditions.** Water entering a power tool will increase the risk of electric shock.
- c. **Do not abuse the cord. Never use the cord for carrying, pulling or unplugging the power tool. Keep cord away from heat, oil, sharp edges or moving parts.** Damaged or entangled cords increase the risk of electric shock.
- d. **When operating a power tool outdoors, use an extension cord suitable for outdoor use.** Use of a cord suitable for outdoor use reduces the risk of electric shock.
- e. **If operating a power tool in a damp location is unavoidable, use a residual current device (RCD) protected supply.** Use of an RCD reduces the risk of electric shock.
- f. **NOTE** The term “residual current device (RCD)” can be replaced by the term “ground fault circuit interrupter (GFCI)” or “earth leakage circuit breaker (ELCB)”.

PERSONAL SAFETY

WARNING

- a. **Stay alert, watch what you are doing and use common sense when operating a power tool. Do not use a power tool while you are tired or under the influence of drugs, alcohol or medication.** A moment of inattention while operating power tools may result in serious personal injury.
- b. **Use safety equipment. Always wear eye protection.** Safety equipment such as dust mask, non-skid safety shoes, hard hat, or hearing protection used for appropriate conditions will reduce personal injuries.
- c. **Prevent unintentional starting. Ensure the switch is in the off-position before connecting to power source and/or battery pack, picking up or carrying the**

tool. Carrying power tools with your finger on the switch or energising power tools that have the switch on invites accidents.

- d. **Remove any adjusting key or wrench before turning the power tool on.** A wrench or a key left attached to a rotating part of the power tool may result in personal injury.
- e. **Do not overreach. Keep proper footing and balance at all times.** This enables better control of the power tool in unexpected situations.
- f. **Dress properly. Do not wear loose clothing or jewellery. Keep your hair, clothing and gloves away from moving parts.** Loose clothes, jewellery or long hair can be caught in moving parts.
- g. **If devices are provided for the connection of dust extraction and collection facilities, ensure these are connected and properly used.** Use of these devices can reduce dust-related hazards.
- h. **Do not let familiarity gained from frequent use of tools allow you to become complacent and ignore tool safety principles.** A careless action can cause severe injury within a fraction of a second.

TOOL USE AND CARE

WARNING

- a. **Use clamps or other practical way to secure and support the workpiece to a stable platform.** Holding the work by hand or against your body is unstable and may lead to loss of control.
- b. **Do not force tool. Use the correct tool for your application.** The correct tool will do the job better and safer at the rate for which it is designed.
- c. **Do not use tool if switch does not turn it on or off.** A tool that cannot be controlled with the switch is dangerous and must be repaired.
- d. **Disconnect battery pack from tool or place the switch in the locked or off position before making any adjustments, changing accessories, or storing the tool.** Such preventive safety measures reduce the risk of starting the tool accidentally.
- e. **Store idle tools out of reach of children and other untrained persons.** Tools are dangerous in the hands of untrained users.
- f. **Maintain power tools and accessories. Check for misalignment or binding of moving parts, breakage of parts and any other condition that may affect the power tool's operation. If damaged, have the power tool repaired before use.** Many accidents are caused by poorly maintained power tools.
- g. **Keep cutting tools sharp and clean.** Properly maintained cutting tools with sharp cutting edges are less likely to bind and are easier to control.
- h. **Use the power tool, accessories and tool bits etc. in accordance with these**

instructions, taking into account the working conditions and the work to be performed. Use of the power tool for operations different from those intended could result in a hazardous situation.

- i. **Keep handles and grasping surfaces dry, clean and free from oil and grease.** Slippery handles and grasping surfaces do not allow for safe handling and control of the tool in unexpected situations.
- j. **When battery pack is not in use, keep it away from other metal objects like: paper clips, coins, keys, nails, screws, or other small metal objects that can make a connection from one terminal to another.** Shorting the battery terminals together may cause sparks, burns, or a fire.
- k. **Maintain tools with care. Keep cutting tools sharp and clean.** Properly maintained tools with sharp cutting edge are less likely to bind and are easier to control.
- l. **Check for misalignment or binding of moving parts, breakage of parts, and any other condition that may affect the tool's operation. If damaged, have the tool serviced before using.** Many accidents are caused by poorly maintained tools.
- m. **Use only accessories that are recommended by the manufacturer for your model.** Accessories that may be suitable for one tool may create a risk of injury when used on another tool.

BATTERY TOOL USE AND CARE

WARNING

- a. **Ensure the switch is in the off position before inserting battery pack.** Inserting the battery pack into power tools that have the switch on invites accidents.
- b. **Recharge only with the charger specified by the manufacturer.** A charger that is suitable for one type of battery pack may create a risk of fire when used with another battery pack.
- c. **Use power tools only with specifically designated battery packs.** Use of any other battery packs may create a risk of injury and fire.
- d. **When battery pack is not in use, keep it away from other metal objects like paper clips, coins, keys, nails, screws, or other small metal objects that can make a connection from one terminal to another.** Shorting the battery terminals together may cause burns or a fire.
- e. **Under abusive conditions, liquid may be ejected from the battery; avoid contact. If contact accidentally occurs, flush with water. If liquid contacts eyes, additionally seek medical help.** Liquid ejected from the battery may cause irritation or burns.
- f. **Do not use a battery pack or tool that is damaged or modified.** Damaged or modified batteries may exhibit unpredictable behaviour resulting in fire,

explosion or risk of injury.

- g. **Do not expose a battery pack or tool to fire or excessive temperature.** Exposure to fire or temperature above 130 °C may cause explosion. NOTE The temperature „130 °C“ can be replaced by the temperature „265 °F“.
- h. **Follow all charging instructions and do not charge the battery pack or tool outside the temperature range specified in the instructions.** Charging improperly or at temperatures outside the specified range may damage the battery and increase the risk of fire.

SERVICE

Have your power tool serviced by a qualified repair person using only identical replacement parts. This will ensure that the safety of the power tool is maintained.

Tool service must be performed only by qualified repair personnel. Service or maintenance performed by unqualified personnel may result in a risk of injury.

When servicing a tool, use only identical replacement parts. Follow instructions in the Maintenance section of this manual. Use of unauthorized parts or failure to follow Maintenance Instructions may create a risk of shock or injury.

SPECIFIC SAFETY RULES AND SYMBOLS

CAUTION

Hold tool by insulated gripping surfaces when performing an operation where the cutting tool may contact hidden wiring. Contact with 'live' wire will also make exposed metal parts of the tool 'live' and shock the operator.

Be aware that this tool is always in an operating condition, because it does not have to be plugged into an electrical outlet. Always set the trigger switch to the locked OFF position when installing or removing the battery pack or bits.

Do not use bits or sockets larger than those recommended. Large bits or drills may overload the wrench/driver and damage the motor and gears.

Do not use if chuck jaws or other parts are cracked or worn.

Never change direction of rotation until motor has completely stopped.

Never hold work in your hand, lap, or against other parts of your body when driving.

Do not use drill as a router or try to elongate or enlarge holes by twisting the drill bit. Drill bits may break and cause injury.



Keep hands away from rotating parts.

Keep drill bit clear of yourself and all objects while installing and removing bit.

Some wood contains preservatives which can be toxic. Take extra care to prevent inhalation and skin contact when working with these materials. Request, and follow, all safety information available from your material supplier.

SYMBOLS

The label on your tool may include the following symbols. The symbols and their definitions are as follows:

SYMBOL	NAME	EXPLANATION
V	Volts	Voltage (potential)
n _o	No Load Speed	No-load Rotational Speed
kg	Kilograms	Weight
 d.c.	Direct Current	Type of Current IEC60417.5031(2002.10)
.../min	Revolutions per Minute	Revolutions, Surface Speed, Strokes, etc. per Minute
rpm	Revolutions per Minute	Revolutions, Surface Speed, Strokes, etc. per Minute
	Number of blow	Impact Speed, Strokes, etc. per Minute

FUNCTIONAL DESCRIPTION

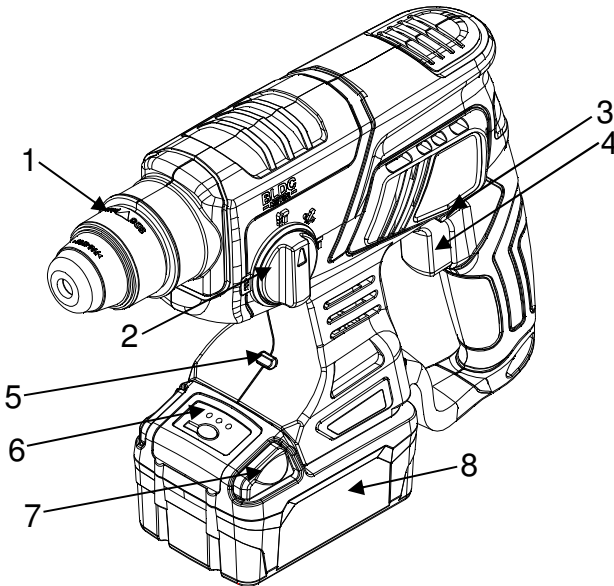

CONTROLS AND COMPONENTS:

- | | |
|---|---|
| <ul style="list-style-type: none"> 1. Quick change chuck for SDS-plus 2. Action mode changing knob 3. Forward / Reverse Control Button 4. Variable Speed Switch | <ul style="list-style-type: none"> 5. Built-in LED light 6. Battery Indicator 7. Release button 8. Battery Pack |
|---|---|

SPECIFICATIONS

Model Number	Unit	RY6001
Voltage	V d.c.	60
Chuck Capacity		SDS-plus
Impact Energy	Joules	2.30
Impact Energy	ft-lbs	1.69
No Load Speed	rpm	0-1700
Blows per Minute	bpm	0-5600
Tool Weight (with battery 2.0Ah)	lbs	5.72
Tool Weight (with battery 2.0Ah)	kg	2.6
Overall length	inch	11.25
Overall length	mm	287

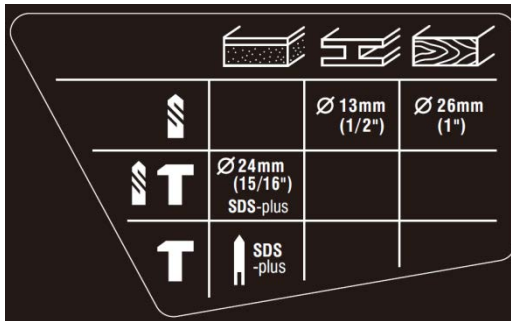

▲ WARNING

- that the vibration emission during actual use of the power tool can differ from the declared total value depending on the ways in which the tool is used; and
- of the need to identify safety measures to protect the operator that are based on an estimation of exposure in the actual conditions of use (taking account of all parts of the operating cycle such as the times when the tool is switched off and when it is running idle in addition to the trigger time).

Charger Model Number	DC60UN26-C10 / DC60UN26-C25
Input	100-240 V a.c., 50~60 Hz
Output	62 V d.c.
Output Amps	1.0A / 2.5A

Input Power	$\leq 75W$ / $\leq 190W$
Battery Pack Model Number	B6029LA
Type	Li-ion
Capacity	2.0Ah

VARIABLE SPEED SWITCH

The variable speed switch provides safety feature to the user for screw driving.

To turn the tool on, squeeze the trigger switch. To turn the tool off, release the trigger switch (see Fig. 1A).

Your tool is equipped with a brake. The chuck will stop as soon as the trigger switch is fully released. The variable speed switch enables you to select the best speed for a particular application. The farther you squeeze the trigger, the faster the tool will operate.

Use lower speeds for starting holes without a center punch, drilling metals or plastic, driving screws and drilling ceramics, or in any application requiring high torque. Higher speeds are better drilling in wood, wood compositions and for using abrasive and polishing accessories. For maximum tool life, use variable speed only for starting holes or fasteners.

NOTE: Continuous use in variable speed range is not recommended. It may damage the switch and should be avoided.

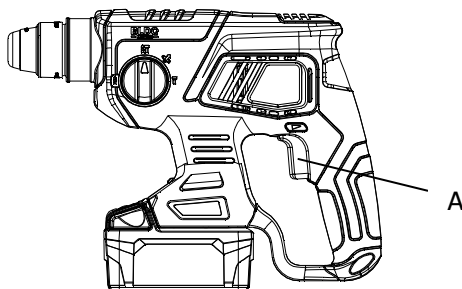

Fig. 1

FORWARD / REVERSE CONTROL BUTTON

A forward/reverse control button determines the direction of the tool and also serves as a lock off button (see Fig. 2B). To select forward rotation, RELEASE THE VARIABLE SPEED SWITCH, and depress the forward/reverse control button, towards the left hand side of the tool. To select reverse, depress the forward/reverse control button, towards the right hand side of the tool. The center position of the control button locks the tool in the OFF position. When changing the position of the control button, make sure the trigger is fully released.

NOTE: The first time the tool is run after changing the direction of rotation, you may hear a click on start up. This is normal and does not indicate a problem.

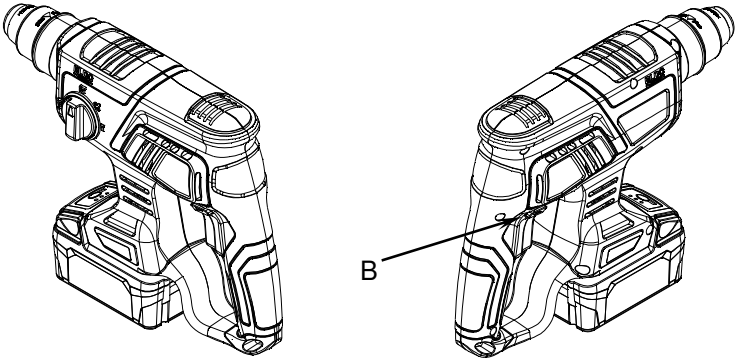



Fig. 2

ACTION MODE CHANGING KNOB

A. Rotation only

For drilling in wood, metal or plastic materials. Rotate the action mode changing knob to the  symbol. Use a twist drill bit or wood bit.

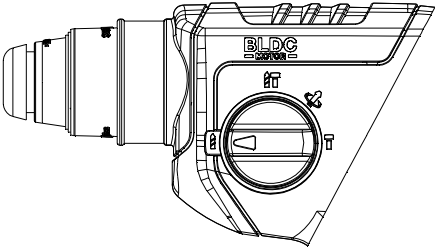



Fig. 3

B. Rotation with hammering

For drilling in concrete, masonry...etc. Rotate the action mode changing knob to the  symbol. Use a tungsten-carbide tipped bit.

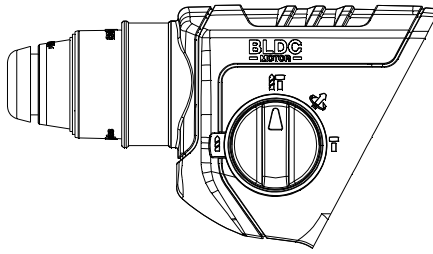

Fig. 4

C. Hamming only

For chipping, scaling or demolition operations. Rotate the action mode changing knob to the □ symbol. Use a bull point, cold chisel, scaling chisel...etc.

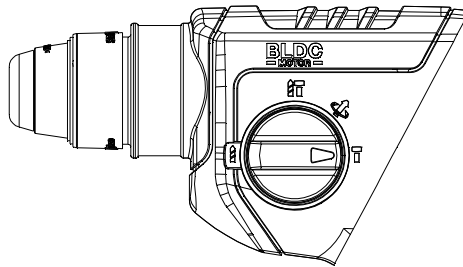

Fig. 5

D. Bit Angle (When chipping, scaling or demolishing)

The bit can be secured at the desired angle. To change the bit angle, rotate the action mode changing knob to the ⚙ symbol. Turn the bit to the desired angle.

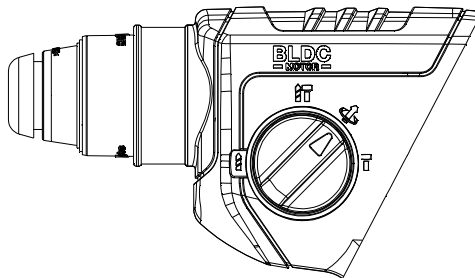
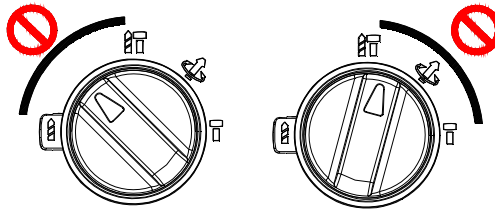





Fig. 6

⚠ CAUTION:

- Do not rotate the action mode changing knob when the tool is running. The tool will be damaged.

- To avoid rapid wear on the mode change mechanism, be sure that the action mode changing knob is always positively located in one of the three action mode position.



- When changing from the  symbol mode to the  symbol mode, the action mode changing knob may no longer move in the  symbol position. At this time, turn the tool on or turn the chuck by hand in the  symbol position and then rotate the action mode changing knob. Forcing the action mode changing knob may cause tool damage.

BUILT-IN LED AREA LIGHT

Your tool has a built-in LED light to illuminate the work area and improve vision when drilling/driving in areas with insufficient light.

ELECTRIC BRAKE

The variable speed switch is equipped with a circuit designed electric brake function. The tool will promptly stop rotating after the switch is fully released – This is the normal function of an electric brake.

ASSEMBLY

INSTALLING OR REMOVING BATTERY PACK

TO REMOVE BATTERY PACK: Depress the battery release button (see Fig. 7C), and pull battery pack out of tool.

TO INSTALL BATTERY PACK: Align rails (see Fig 7B), on the tool with the four tabs on the battery pack, and push battery pack onto tool until it locks in place.

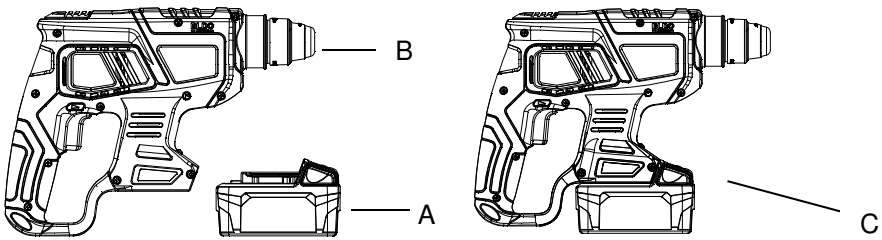

Fig. 7

⚠ CAUTION:

Always be sure that the tool is switched off and the battery cartridge is removed before carrying out any work on the tool.

SIDE GRIP (AUXILIARY HANDLE)

⚠ CAUTION:

Always use the side grip to ensure operating safety. Install the side grip so that the protrusion on the grip fit in between the grooves in the tool barrel. Then tighten the grip by turning clockwise at the desired position. It may be swung 360° so as to be secured at any position.

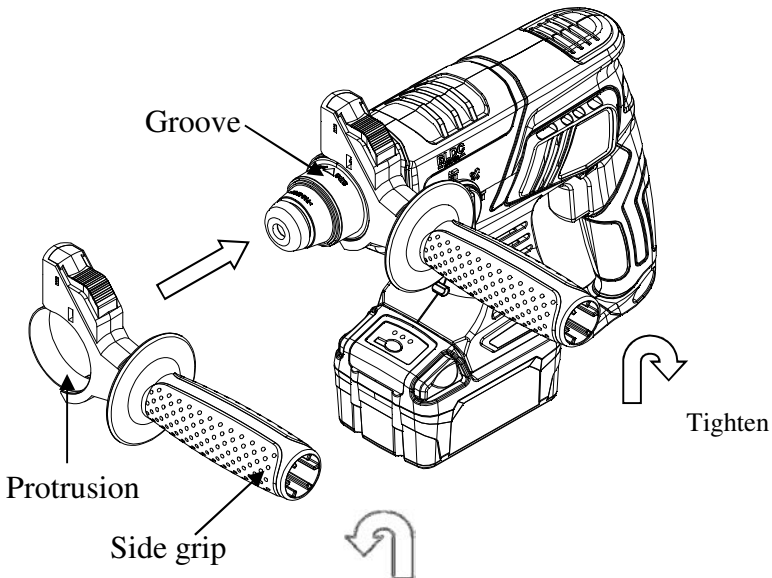

Loosen
Fig. 8

BIT GREASE

Coat the bit shank head beforehand with a small amount of bit grease (about 0.5~1.0 gram / 0.02~0.04oz). This chuck lubrication assure smooth action and longer service life.

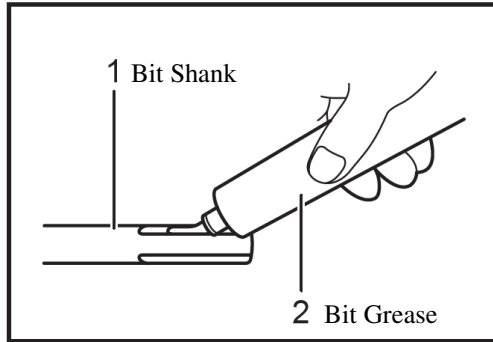

INSTALLING OR REMOVING THE BIT

- Clean the bit shank and apply bit grease before installing the bit.
- Insert the bit into the tool, Turn the bit and push it in until it engages.
- If the bit cannot be pushed in , remove the bit. Pull the chuck cover down a couple of times. Then insert the bit again. Turn the bit and push it in until it engages.
- After installing, always make sure that the bit is securely held in place by trying to pull it out.
- To remove the bit, pull the chuck cover down all the way and pull the bit out.

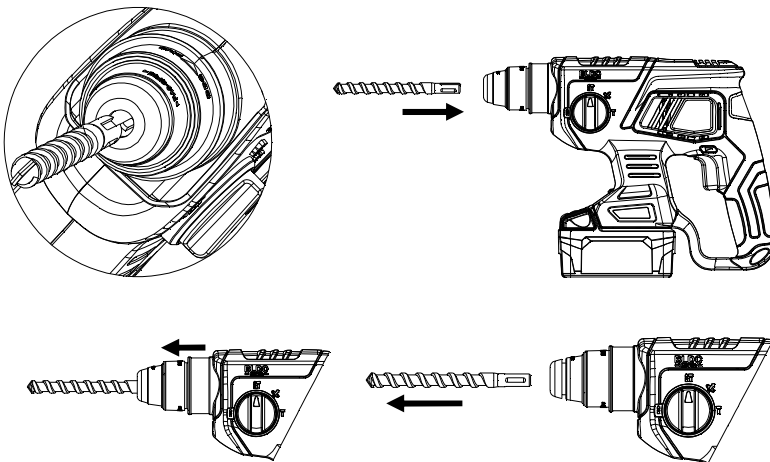

Fig. 9

INSTALLING THE DEPTH GAUGE

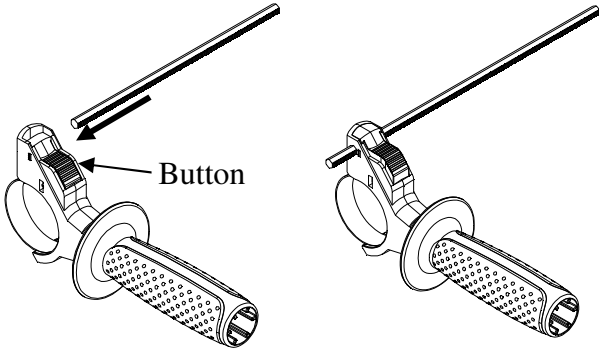

Fig. 10

The depth gauge is convenient for drilling holes of uniform depth. Press the button and insert the depth gauge into the hole in side grip. Adjust the depth gauge to the desired depth and release the button to fix the gauge.

NOTE:

The depth gauge cannot be used at the position where the depth gauge strikes against the gear housing.

BATTERY POWER INDICATOR

Trigger the tool and Battery Indicator to show the battery pack's remaining capacity

1. One light ON: 30% remaining capacity.
2. Two lights ON: 60% remaining capacity.
3. All lights ON: 100% remaining capacity.



OPERATION

NOTE

Always check the direction of the rotation before use.

HAMMER DRILLING OPERATION

- Set the action mode changing knob to the  symbol.
- Position the bit at the desired location for the hole, then depress the switch trigger.
- Do not force the tool. Light pressure gives best results.

- Keep the tool in position and prevent it from slipping away from the hole.
- Do not apply more pressure when the hole becomes clogged with chips or particles, Instead, run the tool at an idle, then remove the bit partially from the hole. By repeating this several times, the hole will be cleaned out and normal drilling may be resumed.

⚠ CAUTION:

There is a tremendous and sudden twisting force exerted on the tool/bit at the time of hole break-through, when the hole becomes clogged with chips and particles, or when striking reinforcing rods embedded in the concrete. Always use the side grip (auxiliary handle) and switch handle during operations. Failure to do so may result in the loss of control of the tool and potentially severe injury.

NOTE:

Eccentricity in the bit rotation may occur while operating the tool with no load. The tool automatically centers itself during operation. This does not affect the drilling precision.

BLOW-OUT BULB (OPTIONAL ACCESSORY)

After drilling the hole, use the blow-out bulb to clean the dust out of the hole..

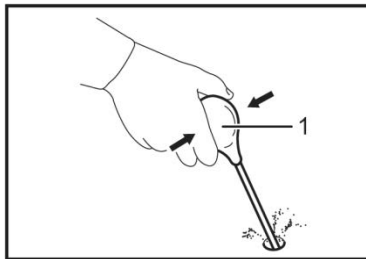

CHIPPING / SCALING / DEMOLITION

Set the action mode changing knob to the  symbol.

Hold the tool firmly with both hands. Turn the tool on and apply slight pressure on the tool so that the tool will not bounce around, uncontrolled. Pressing very hard on the tool will not increase the efficiency.

DRILLING IN WOOD OR METAL

Use the optional drill chuck assembly. When installing it, refer to “installing or removing the bit” described on the previous page.

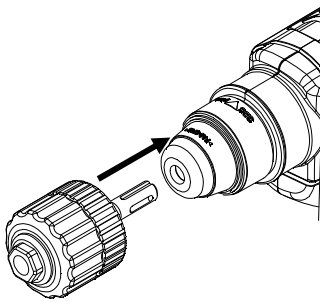

Set the action mode changing knob to the  symbol.

⚠ CAUTION:

Never use “rotation with hammering” mode when the drill chuck assembly is installed on the tools. The drill chuck assembly maybe damaged. Also the drill chuck will come off when reversing the tool.

Use the quick change drill chuck as standard equipment.

When installing it, refer “installing or removing the bit” described on the previous page.

- Hold the ring and turn the sleeve counterclockwise to open the chuck jaws. Place the bit on the chuck as far as it will go.

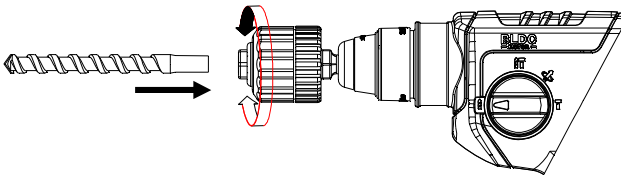

- Hold the ring firmly and turn the sleeve clockwise to tighten the chuck.

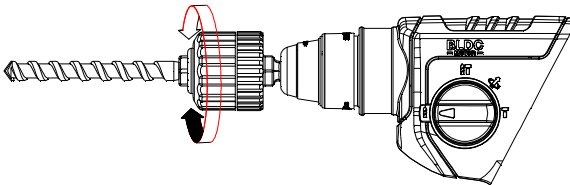

- Set the action mode changing knob to the  symbol. You can drill up to 13mm(1/2”) dia. in metal and up to 26mm(1”) dia. in wood.

CAUTION:

- Never use “rotation with hammering” mode when the drill chuck assembly is installed on the tools. The drill chuck assembly maybe damaged. Also the drill chuck will come off when reversing the tool.
- Pressing excessively on the tool with not speed up the drilling. In fact, this excessive pressure will only serve to damage the tip of your bit, decrease the tool performance and shorten the service life of the tool.
- There is a tremendous twisting force exerted on the tool/bit at the time of hole breakthrough. Hold the tool firmly and exert care when the bit begins to break through the workpiece.
- A struck bit can be removed simply by setting the reversing switch to reverse rotation in order to back out. However, the tool may back out abruptly if you do not hold it firmly.
- Always secure small workpieces in a vise or similar hold-down device.

MAINTENANCE

WARNING

Remove the battery pack from this tool before cleaning solutions.

NOTE

This tool is lubricated before it leaves the factory. This lubrication should last for the life of the tool. No further lubrication is required.

CLEANING

With the motor running, blow dirt and dust out of all air vents with dry air at least once a week. Wear safety glasses when performing this. Exterior plastic parts may be cleaned with a damp cloth and mild detergent. Although these parts are highly are solvent resistant, NEVER use solvent.

CHARGER CLEANING INSTRUCTIONS

Dirt and grease may be removed from the exterior of the charger using a cloth or soft non-metallic brush. DO NOT use water or any cleaning solutions.

WARNING!!!: Disconnect the charger from the AC outlet before performing any cleaning of the charger.

ACCESSORIES

Use only accessories that are recommended by the manufacturer for your model. Accessories that may be suitable for one tool may become hazardous when used on another tool.

Recommended accessories for use with your tool are available at extra cost from your local service center.

IMPORTANT: To assure product SAFETY and RELIABILITY, repairs, maintenance and adjustments should be performed by certified service centers or other qualified service organizations, always using identical replacement parts.

PROTECTING THE ENVIRONMENT

Before disposing of damaged, check with your state Environmental Protection Agency to find out about special restrictions on the disposal of tool or return them to a certified service center for recycling.



Durofix



For technical support, call: 886-4-25683366

Service address: Mobiletron Electronics Co., Ltd.

No. 85, Sec. 4, Chung-Ching Rd.
Ta-Ya, Taichung, 428, Taiwan

www.durofix.com.tw